



**CENTRAL INSTITUTE OF MINING & FUEL RESEARCH**  
(CSIR, Ministry of Science & Technology, Govt. of India)  
H.Q.: Barwa Road Campus, Dhanbad – 826 015 (Jharkhand), India

NIT No.CIMFR/PUR/14(3)2010

Date:25.11..2010

**NOTICE INVITING TENDER**

Director, CIMFR invites sealed tenders (In two Bid Systems) for supply, installation and commissioning of **Thermo Gravimetric Analyzer (TGA)**.

Item No.	Particulars of Item	Qty.
1.	<b>Thermo Gravimetric Analyzer (TGA)</b> File No:13(2)/CIMFR-BU/57/10-11/PUR	One Unit
<b>Last Date of Submission : 27.12.2010</b> <b>Time: Up to 3.00 P.M.</b> <b>Date of Opening : 28.12.2010</b> <b>Time: 3.00 PM onwards</b> Details of the Tender Document is available at <a href="http://www.cimfr.nic.in">www.cimfr.nic.in</a>		
2	File No:- CIMFR/PUR/-14(19)2010 Director, CIMFR is interested to procure <b>Vehicle Mounted (portable) Gas Analyzer System</b> for measuring Gases Emissions from Coal Mine Fire areas located in Jharia & Ranigaj Coal field. All those interested/prospective bidders are invited/ requested to kindly send their consent on or before 13.12.2010 for participating in this <b>Pre-indent conference schedule to be held on 14.12.2010 ( 11.00 A.M) at CIMFR, Barwa Road, Dhanbad.</b> For details please visit our website <a href="http://www.cimfr.nic.in">www.cimfr.nic.in</a>	One Unit

☎ : 0326- 2388306/2388319

☎ : 0326- 2296030/2381210

s/d  
S.P.O.  
For Director



**CENTRAL INSTITUTE OF MINING & FUEL RESEARCH**  
(CSIR, Ministry of Science & Technology, Govt. of India)  
H.Q.: Barwa Road Campus, Dhanbad – 826 015 (Jharkhand), India

NIT No.CIMFR/PUR/14(3)2010

Date:25.11..2010

**NOTICE INVITING TENDER**

**Detailed specifications:-**

Item No.	Particulars of Item	Qty.
1.	<p>File No:13(2)/CIMFR-BU/57/10-11/PUR <b>Thermo Gravimetric Analyzer (TGA)</b></p> <ol style="list-style-type: none"><li>Working Temperature: Ambient-1000° C ( Max &amp; programmable)</li><li>Programmable ramp rate : 25° – 50° C</li><li>Temperature stability : <math>\pm 2^{\circ}</math> C</li><li><b>Maximum sample load : 25-40 samples per cycle. ( Preferably maximum load taking instrument)</b></li><li>Programmable Set: At least 5 programmable facility for moisture ash, Volatile and fixed carbon at different temperature.</li><li>X-haust: System To expel combusted gas from instrument.</li><li>Atmosphere of determination: Oxidizing and Inert.</li><li>Power to the instrument: 230<math>\pm</math> 30 volts, 50/60htz</li><li>Sample size: 0.5-1.5 gms.</li></ol> <p style="text-align: center;"><b>With</b></p> <p><b>Built in window based professional software. With computer &amp; printer as required.</b></p> <p><b><u>Operating supplies for 2 years: ( 5000 samples approx.)</u></b></p> <ol style="list-style-type: none"><li>Standard sample,</li><li>Crucible</li><li>Crucible Cover</li><li>Turn Table and any other part of instrument which is likely to disrupt continuous working.</li></ol>	One Complete Unit
<p style="text-align: center;"><b>Last Date of Submission : 27.11.2010                      Time: Up to 3.00 P.M.</b> <b>Date of Opening : 28.11.2010                                      Time: 3.00 PM onwards</b> <b>Details of the Tender Document is available at <a href="http://www.cimfr.nic.in">www.cimfr.nic.in</a></b></p>		



**CENTRAL INSTITUTE OF MINING & FUEL RESEARCH**  
(CSIR, Ministry of Science & Technology, Govt. of India)  
H.Q.: Barwa Road Campus, Dhanbad – 826 015 (Jharkhand), India

NIT No.CIMFR/PUR/14(3)2010

Date:25.11..2010

**NOTICE INVITING TENDER**

Director, CIMFR invites sealed tenders (In two Bid Systems) for supply, installation and commissioning of Thermo Gravimetric Analyzer (TGA).

Item No.	File No.	Particulars of Item	Qty.	T.D. Fee in DD*	EMD in DD/BG/BC
1.	File No:13(2)/CIMFR-BU/57/10-11/PUR	Supply and Installation of Thermo Gravimetric Analyzer (TGA)	01 Unit	Rs.300.00	Rs76,000/-

\* No tender fees are required in case it is downloaded from the site [www.cimfr.nic.in](http://www.cimfr.nic.in).

**Note:** The Tender Document can be obtained from the Office of the Stores & Purchase Officer, CIMFR, Barwa Road, Dhanbad on written request on payment of the non- refundable and non – transferable tender document fees as stated above in the form of cross Demand Draft issued by a scheduled bank drawn in favour Director, CIMFR, payable at State Bank of India, Hirapur Branch, Dhanbad from **29.11.2010 to 27.12.2010 upto 3 PM**. CIMFR will not be responsible for non- receipt of the Tender Documents due to postal delay/loss in transit. The tender complete in all respect along with EMD should reach to this office on or before **27.12.2010 before 3.00 PM** and will be opened on **28.12.2010 after 3.00 PM** onwards at CIMFR H.Q.

Tender Documents with detail terms & conditions can be downloaded from our website: [www.cimfr.nic.in](http://www.cimfr.nic.in) . Tender fees will not be required if it is downloaded from the website up to the tender sale period. The required EMD as stated above in the form of DD or BG must be enclosed in the Technical Bid failing which the offer will be treated as non-responsive.

Director, CIMFR reserve the right to accept or reject in part or in full to any or all the tender without assigning any reason thereof.

☎: 0326- 2388306/2388319

☎: 0326- 2296030/2381210

S/d  
S.P.O / S.O.(S&P)  
For Director



# Central Institute of Mining & Fuel Research

**Erstwhile Central Mining Research Institute  
(Council of Scientific & Industrial Research)  
Barwa Road Campus, Dhanbad –826015 (Jharkhand), INDIA**

---

## **COMMERCIAL TERMS & CONDITIONS**

### **Important Notice**

The Commercial Terms & Conditions is given in five different sections, which may please read carefully before submitting the tender. Any deviation and non-compliance of the terms & conditions must be written clearly. An incomplete offer and late bids are liable to be ignored and rejected. To aid the Bidders in submitting complete offers, a Check List is included in the bid document. The bidders must fill this and submit along with their offer in their own interest to avoid rejection of their tender.

### **Request For Proposal (RFP)**

**NIT No.**

**CIMFR/PUR/14(1)2010**

1.Last Date for Submission of Bid :

**30.08.2010 upto 4.00 P.M**

2.Date of Opening of Tender(only Technical Bid in case of Double Bid System)

**31.08.2010 at 10.30 A.M**

3.Date of Opening Financial Bid wherever applicable : TENDERERS WHOSE TENDERS ARE  
FOUND TECHNICALLY SUITABLE

## **SECTION - I**

### **INVITATION FOR THE BIDS**

Sealed tenders are invited under **Two Bids System** 1. Technical-Commercial Bid and 2. Financial Bid for the products mentioned in our Global / Open Tender Notice required to be supplied, installed, commissioned and demonstrated at CIMFR, Dhanbad. **Technical- Commercial Bid and Financial Bid should be identical in all respects except that the Technical-Commercial Bid should have blank space at the place where prices have been indicated in the Financial Bid.**

Tenderers are requested to submit their tenders in three separate envelopes 1. EMD Envelope, 2. Technical-Commercial Bid Envelope and 3. Financial Bid Envelope duly sealed and super scribed with "Tender No. and Description of item" strictly as per our Technical specifications and Terms and Conditions.

**Technical-Commercial Bid** should consist of:

1. Technical specifications being offered by the firm of Tender Documents along with Brochures and literature giving all features.
2. Certificate of Registration of firm
- 3. Authorization Letter from the manufacturer to quote and submit tender.**
4. Certificate of valid Authorised Distributorship/Dealership/Retailer ship from the manufacturer.
5. Latest Income Tax Clearance Certificate
6. Certificate of Central Sales Tax/Local Sales Tax Registration No. Authorised Service Provider Certificate from the Manufacturer only.
- 7. Photocopy of Warranty Service Provider Agreement between the manufacturer and the Service Provider.**
8. Clients list along with addresses, Telephone Nos., Fax Nos., Contact persons. Product supplied, Qty. supplied, Performance Certificates/Bench marking of the equipments by recognized National/Institutional/ Govt. organization like Department of Electronics.
9. Last Audited Balance Sheet of the firm.
10. Maintenance Infrastructure Facilities including addresses, Telephone No. of Service Centre.
11. Photocopy duly attested of Certificate of compulsory enlistment of Indian Agents of Foreign Principals with DGS&D (**wherever required**) quoting on their behalf. Date of enlistment must be before the date of opening of tenders.
12. Details of Equipments supplied of identical or similar nature to other CSIR Labs/Institute for the preceding three years along with the prices eventually or finally paid.

### **Commercial Terms :**

- a. Percentage rate of CST/LST, Octroi, freight and forwarding charges, handling charges, loading/unloading charges, any other tax/charge as applicable should be clearly mentioned. The offers indicating "Taxes as applicable" or "Taxes inclusive" may be rejected.
- b. Validity of Quotation
- c. Delivery Period
- d. Payment Terms
- e. Warranty
- f. Training
- g. Discount
- h. Terms of Delivery
- i. Post Warranty AMC
- j. Performance Security Deposit
- k. Liquidated Damages
- l. Installation, testing and commissioning charges
- m. Percentage of Agency Commission in case of imports.
- n. Agency Commission should be included in the FOB Price and will be paid to the Indian Agents if registered with DGS&D (**wherever required**)
- o. Gateway Airport in case of shipment from abroad
- p. Beneficiary Bank and SWIFT No. in case of imports

**Financial Bid** should consist of:

**Basic Price** in case of indigenous supply/FOB price in case of imports

### **Commercial Terms**

a. Percentage rate of CST/LST, Octroi, freight and forwarding charges, handling charges, loading/unloading charges, any other tax/charge as applicable should be clearly mentioned. The offers indicating "Taxes as applicable" or "Taxes inclusive" may be rejected.

b. Validity of Quotation

c. Delivery Period

d. Payment Terms

e. Warranty

f. Training

g. Discount

h. Terms of Delivery

i. Post Warranty AMC

j. Performance Security Deposit

k. Liquidated Damages

l. Installation, testing and commissioning charges

m. Percentage of Agency Commission in case of imports.

Agency Commission should be included in the FOB Price and will be paid to the Indian Agents if registered with DGS&D (**wherever required**).

n. Gateway Airport in case of shipment from abroad

o. Beneficiary Bank and SWIFT No. in case of imports

The bids complete in all respects addressed to the Director, CIMFR should reach at the following address **latest by 4.00 PM on 30.08.2010.**

### **Central Institute of Mining & Fuel Research**

**Erstwhile Central Mining Research Institute**

**(Council of Scientific & Industrial Research),**

**Barwa Road Campus, Dhanbad -826015, JHARKHAND, INDIA**

**☎: 0091-0326-2296030, 📠: 0326-2296030,2202429**

**STD CODE: 0326**

**The Tenders (Technical Bids only wherever applicable) will be opened in this Office at 10.30 A.M hours on 31.08.2010 in the presence of Bidders (only one representative of the firm) who is willing to participate in the tender and whose EMD is in order.**

## **SECTION - II**

### **INSTRUCTION TO BIDDERS**

#### **1. Scope of Work:**

Supply installation, testing, commissioning, demonstration and training in the usage and administration of procurement of products mentioned in our Open Tender Notice.

#### **2. Bidders:**

The invitation for Bid is open to all Indian Original Equipment Manufacturers / Authorized Distributors/Authorized Dealers/Authorized Retailers/Foreign Manufacturers or suppliers directly/authorized Indian Agents. In such cases where the tenders are submitted by the Indian Agents of their Foreign Manufacturer/Supplier or directly by the Principal to CIMFR, then the tender of Foreign Manufacturer/Supplier will only be considered and CIMFR will deal directly with the Foreign Manufacturer/Supplier or otherwise as decided by Director' CIMFR.

#### **3. Cost of Bidding:**

The bidders shall bear all costs associated with the preparation and submission of its bid and CIMFR will in no case be responsible or liable for these costs regardless of the conducts and the outcome of the bidding process.

#### **4. The Bidding Documents:**

The goods and services required, bidding procedures and contract terms are prescribed in the bidding document. In addition to the invitation for the bids, the bidding document includes:

- a) Instruction to bidders
- b) Schedule of requirements
- c) Technical Specifications
- d) Terms & Conditions
- e) Bid form and price schedule

The bidder is expected to examine all instructions, forms, terms and conditions in the bidding document. Failure to furnish all information required or submission of bid not substantially responsive to the bidding documents in every respect will be at the bidder's risk and may result in rejection of its bid.

#### **5. Preparation of bids:**

The bids are to be submitted in three separate sealed envelopes

- a) Earnest Money Deposit
- b) Technical-Commercial Bid
- c) Financial Bid

#### **6. Submission of Bids :**

##### **a) Sealing and Marking of Bids**

- i) The bids shall be submitted in three separate sealed envelopes addressed to **The Director, Central Institute of Mining & Fuel Research , Barwa Road, DHANBAD-826015 JHARKHAND, INDIA** which shall be marked as "EMD", "Technical-Commercial Bid" and "Financial Bid" mentioning Tender Number, Description of Item and Date of Opening and all the three envelopes should be put inside the big envelope.
- ii) The Envelopes shall indicate the name and address of the bidder to enable the bid to be returned unopened in case it is declared late and delayed.

Telex, cable, facsimile and unsigned bids will not be considered and rejected.

## **b) Deadline for submission of Bids**

i) Bids must be received by CIMFR at the address given in Section-I not later than the time and date specified on the cover page. In the event of the specified date for the submission of bids being declared a holiday for CIMFR, the bids will be received up to the appointed time on the next working day.

ii) The Director, CIMFR may at his discretion extend the deadline for submission of bids by amending the bid documents, in which case all rights and obligations of the purchaser and bidders previously subject to the deadline will thereafter be subject to the deadline as extended.

## **c) Late Bids**

Any bid received after the deadline for submission of bids prescribed by CIMFR will be rejected and/or returned unopened to the bidder.

## **d) Bid Opening and Evaluation**

### **Opening of Technical Bids by Purchaser**

The Purchaser will open all Technical-Commercial Bids, if the EMD, is submitted as per requirement in the presence of bidders' representatives who choose to attend, at the time, on the date and venue indicated in Section-I. The bidders' representatives present there, shall sign a register evidencing their attendance. In the event of the specified date of the bid opening being declared a holiday for the Purchaser, the bids shall be opened at the appointed time and location on the next working day.

## **e) Clarification of Bids**

i) During evaluation of the bids, the purchaser may at his discretion ask the Bidder for clarification of bids. The request for clarification and the response shall be in writing and no change in price or substance of the bid shall be sought, offered or permitted.

ii) No Bidder shall contact the Purchaser on any matter relating to its bid from the time of the bid opening to the time the contract is awarded. If the Bidder wishes to bring additional information to the notice of the Purchaser, it should be done in writing.

iii) Any effort by a Bidder to influence the Purchaser in its decisions on bid evaluation, bid comparison or contract award decision may result in rejection of the Bidder's bid.

## **f) Evaluation of Technical Bid**

i) Prior to the detailed technical evaluation the purchaser will determine the substantial responsiveness of each bid to the Bidding Documents. A substantially responsive bid is one that conforms to all the terms and conditions of the Bidding Documents without material deviations.

ii) A bid determined as not substantially responsive will be rejected by the purchaser and may not subsequently be made responsive by the Bidder by correction of the non-conformity.

iii) All the vendors will have to bring their equipment/machine for testing and technical evaluation/benchmarking as and when asked for, if required. Separate communication will be sent in this regard.

The bidders short listed by the purchaser based on evaluation of their technical bids may be called for detailed discussion including presentation of their equipment system to a team selected by the purchaser for the purpose, at a specified date, time and venue, if needed.

### **g) Opening of Financial Bids**

i) The purchaser will open the financial bids of only those bidders, which are found to be technically qualified to undertake the job. The time, date and venue of opening of financial bids will be intimated to these technical qualified bidders only.

ii) The Financial Bids of the technically qualified bidders shall be opened in the presence of their representatives, who are willing to participate, on the specified date, time and venue.

### **h) Evaluation and Comparison of Bid**

i) The comparison shall be of all inclusive price of goods, inclusive of all costs as well as taxes paid or payable and the warranty period asked for.

ii) Arithmetical errors will be rectified on the following basis: if there is a discrepancy between the unit price and the total price that is obtained by multiplying the unit price and quantity the unit price shall prevail and the total price shall be corrected. If the supplier does not accept the correction of errors, its bid will be rejected. If there is a discrepancy between words and figures, the amount in words will prevail.

iii) Bidders shall state their bid price for the payment schedule. Bids will be evaluated on the basis of this base price. Bidders are however, permitted to state an alternative payment schedule and indicate the reduction in bid price they wish to offer for such alternative payment schedule. The purchaser may consider the alternative payment schedule offered by the selected Bidder but it may not be binding on purchaser.

### **i) Placement of Purchase Order**

The purchaser will place the purchase order on the successful bidder whose bid has been determined to be substantially responsive and has been determined as the best evaluated bid provided further that the bidder is determined to be qualified to perform the contract satisfactorily.

## **SECTION - III**

### **TERMS & CONDITIONS**

**1. Submission of Tenders:** Sealed tenders must be submitted in an envelope duly super scribing "Tender/File Ref.No., Description of item and Date of Opening" addressed to **The Director, Central Institute of Mining & Fuel Research, Barwa Road, Dhanbad - 826015 JHARKHAND, INDIA** in the Tender Box kept in the Office of the Stores & Purchase Officer, CIMFR, **latest by upto 4.00 PM on 30.08.2010 positively. Request for extension of submission date of tenders will not be considered.**

**2. Late/delayed tenders :** Late/delayed tenders due to any reason whatsoever will not be accepted / considered at all under any circumstance.

**3. Opening of Tenders:** The tenders received will be opened at **10.30 A.M.** on **31.08.2010** in the presence of the authorized representatives, if any, of quoting firm (one member only) at this office. **Request for extension of opening date of tenders will not be considered.**

**4. Earnest Money Deposit:** Tenderers shall have to deposit EMD of amount mentioned in our Global / Open Tender Notice in **Indian Rupees** or in equivalent amount in foreign currency in the form of Crossed Demand Draft/BG only in favour of Director, CIMFR, Dhanbad, issued by Scheduled/Nationalized Bank payable at Dhanbad, India, along with their tenders (with Technical Bid only). **The validity of the EMD submitted in the form of Bank Guarantee must be co-terminous with the validity of the offer. It must normally be valid for six months (180 days) from the date of opening of tender. Tenders received without earnest money will not be entertained/ considered at all and rejected summarily. Tenders received along with EMD in the form of Cheque/Cash will not be accepted/ considered and rejected.**

**Firms registered with DGS&D and NSIC may be exempted from payment of EMD if the product being quoted is actually manufactured by them and the product is registered with these agencies. Firms registered with these agencies selling products of other companies and not manufacturing the products being quoted by them are not allowed exemption from payment of EMD. Firms are to submit a legible photocopy duly attested, of Registration Certification of the products manufactured and registered with DGS&D and NSIC for availing EMD exemption before opening of Technical-Commercial Bids, otherwise tender submitted by them will not be considered and rejected summarily.**

**5. Forfeiture of EMD:** The earnest money deposited (EMD) will be forfeited if the vendor withdraws or amends, impairs and derogates from the tender in any respect within the period of validity of tender or fails to furnish the Performance Security Deposit as per Clause No. 6 - Performance Security Deposit mentioned below.

**6. Performance Security Deposit:** The successful tenderer will have to furnish an unconditional Performance Bank Guarantee in favour of the Director, CIMFR, Dhanbad valid up to sixty (60) days after the warranty from a Scheduled/Nationalised Bank in India for 10% of the total order value within twenty one (21) days of the placement of order for orders where full payment is to be made on Letter of Credit/Sight Draft or on delivery, failing which the purchase order/contract shall be terminated.

b. The successful tenderer will have to furnish an unconditional Performance Bank Guarantee in favour of the Director, CIMFR, Dhanbad valid up to sixty (60) days after the warranty from a Scheduled/Nationalised Bank in India for 10% of the total order value before the release of final payment where payment is to be made on satisfactory supply, installation, testing, commissioning, demonstration and final acceptance of the products.

**7. Refund of Performance Security Deposit:** The Performance Security Deposit will be returned to the successful vendor after sixty days from the date of the completion of warranty period and no interest would be paid thereon.

**8. Warranty:** Equipments should be under free ONSITE comprehensive warranty for a minimum period of three years from the date of completion of satisfactory installation, testing, commissioning, demonstration and final acceptance of the products. A satisfactory service during the warranty period is defined as 95% uptime. In case 95% uptime is not provided, the warranty period would be extendable by a period which is equivalent to the period during which 95% uptime was not provided. **The bidder will also ensure that the spares are available at least for three years after the warranty period for the operation and maintenance of the equipments supplied. The firms giving the warranty offer less than three years must specify the equivalent amount to be charged for additional warranty/per year which will be added to the price quoted for deciding Lowest Tender. Failing to quote the same will lead to rejection of the bid. This must be strictly complied.**

**9. Custom Duty and Excise Duty:** Our Institution is eligible for payment of concessional Custom Duty and exempted from payment of Excise duty.

a) In case, the tenderers are Indian Agents of the foreign suppliers and quoting prices on behalf of their foreign principals must enclose the proof of enlistment with DGS&D (**wherever required**). Date of enlistment must be before the date of opening of tenders. Tenders of agents not enlisted with DGS&D will be ignored and summarily rejected. The compulsory enlistment of Indian Agents of foreign principals with DGS&D is of general nature and does not confer on the Indian Agents the status of a supplier registered with DGS&D.

b) In case, the prices are quoted in foreign currency, it must be on FOB price. Indian Agency Commission/Technical Service Charges, if any, must also be shown separately and shall be payable in India in Indian Rupees only if the Indian Agent is registered with DGS&D. Kindly indicate Indian Agent's address, their kind of services and percentage Agency Commission (which will be reduced from invoice and paid in Indian Rupees Only). Also quotation should indicate whether Agency Commission is included / excluded in the FOB price.

c) In case of Domestic, the offer should contain the basic price and percentage of Excise Duty separately since we are exempted from payment of Excise Duty.

**10. Prices:** The price quoted should clearly mention whether

- a) **FOR destination /Dispatching Station by registered road transport**
- b) **FOR free delivery at this office Stores including Packing & Forwarding, freight, insurance charges, etc.**
- c) **Where there is no mention of the above, the offers will be rejected as incomplete.**
- d) **In case of Imports, the quotation should be for FOB price only.**

**11. Taxes:** The percentage rate of sales tax, resale tax, duties/levies and any other charges etc, should be clearly indicated in the tender, wherever chargeable. The packing charges must be included in the rates. **CIMFR is not authorized to issue C/D Forms.** However, the concessional rate of central sales tax is admissible to Research Institutions from certain States is also applicable to this Institute and necessary Concessional Sales Tax Certificate will be issued. The supplier should submit documentary proof while claiming octroi, naka etc. charges.

**12. Annual Maintenance Contract:** After the expiry of warranty period, ONSITE Comprehensive Maintenance Contract may be entered into for which the Annual Maintenance Contract (AMC) charges should invariably be quoted in terms of percentage (%) of cost on the exact amount inclusive of all taxes and duties of the product to be supplied.

Satisfactory services during AMC period is defined as 95% uptime. In case 95% uptime is not provided the AMC period would be extendable by a period which is equivalent to the period during which 95% uptime was not provided.

Response Time : Should be four hours

**Preventive Maintenance:** Tenderers should provide at least one preventive maintenance service every month during the AMC period.

**13. Training:** Tenderers should provide free training on the complete operation and care of the equipment and Software Packages to be supplied on mutually agreed terms.

**14. Validity of Tender:** The quotations shall be valid for a minimum period of **One Hundred Eighty (180) days from the date of opening of tenders.**

**15. Delivery:** Equipment may be delivered between 11.00 A.M. to 04.00 P.M. on all working days i.e. Monday to Friday at our Stores Section only.

**16. Payment - Indigenous Supplier:** Payment shall be made after delivery, satisfactory installation, testing, commissioning, demonstration and final acceptance of the ordered items by the user department, through an Account Payee cheque drawn on **State Bank of India, Hirapur Branch, Dhanbad-826 015 (Jharkhand)**, India within thirty (30) days from the date of submission of the bill. Bill(s) in triplicate duly pre-receipted with Rs.1/- revenue stamp will have to be presented for claiming payments.

**17. Liquidated Damages:** The LD clause of 01% per week subject to maximum 10% of the order value will be imposed on non-compliance of the order Terms & Conditions. The L.D may further be revised and enhanced as per the discretion of the Competent Authority, CIMFR on violation of the contractual terms of any form. Director, CIMFR reserves the right to go ahead with the procurement of ordered goods from any another vendor without giving any prior notice and cancel the purchase order. In such case, any additional impact on CIMFR over and above that contained in the Purchase Order shall be recovered from the successful vendor from the payment to be made by CIMFR or any of the CSIR Labs. to them towards earlier supplies, EMD or otherwise

**18 S.T. Registration No./ITCC/Distributorship/Dealership/Service Provider Certificates:**

Tenderers must attach a legible photocopy of the following documents positively along with their tenders.

- i) CST/Local Sales Tax Registration Certificate.
- ii) Latest Income Tax Clearance Certificate.
- iii) Authorised Distributorship/Authorised Dealership/Authorised Retailership/Authorised Service Provider Certificate from the manufacturers.

**19. Environmental conditions for the installation of equipments:** Tenderers should specify minimum environmental needs for installation of their Equipments such as air-conditioning specifications, power supply specifications including any special requirements like voltage regulators, etc.

**20. Software installation:** Tenderers should clearly specify the minimum hardware requirements for the installation of Software Packages positively.

21. Tenderers should note that they should offer their best products pertaining to Technical specifications given.

22. Tenderers should clearly indicate whether they are Original Equipment Manufacturers or authorized distributors/dealers/suppliers on behalf of manufacturers. Brand names & Model Nos. of all equipments and components offered should necessarily be mentioned.

23. Tenderers should furnish the experience of their organization in the area of manufacturing and/or supply of similar equipment.

**24. Tenderers should have a well established Office and Service and Support Centre in Kolkata / Dhanbad, India,** managed by qualified maintenance professionals along with documentary evidence to be attached with their tenders.

25. Tenderers should indicate the names (along with addresses, Telephone nos., Fax No., Contact person, dates of supply, etc.) of various Government, Public Sector Departments and other organizations where they have supplied and installed the similar equipments and are duly maintaining them.

26. Tenderers should furnish all details of Performance Certification/Bench marking of their Equipments by recognized National/International Institutes Govt. Organizations like D.O.E. (Dept of Electronics), etc as applicable.

27. All prices shall be quoted clearly both in figures and words duly taking into account all concessions provided by the Govt. of India as on the date of tender. In case of discrepancy in Unit and Total prices, unit price shall be taken to be final price for the purpose of calculations.

28. Tenders incorporating additional conditions are liable to be rejected.
29. Complete details including final specifications of the equipments offered/quoted should be furnished along with brochures/literature mentioning all features.
30. Tenderers should indicate whether they are the OEMs/. Authorised Distributors/Authorised Dealers/Authorised Retailer of the equipments offered and have valid license to sell Equipment.
31. Tenderers will also indemnify CIMFR against all possible damage due to any Copyright violation by them.
- 32 Only legal and authorised copy of Software Packages with all original manuals, installation and performance guide, etc. complete in all respects are required to be supplied.
33. Tenderers will replace equipments in toto, in case of any malfunctioning or other similar problems arise after supply of the equipment.
34. Equipment supplied will include all Operational and Maintenance Manuals, tutorials, reference manuals, installation and performance guide, etc. complete in all respects. Connecting cable and/or any other part/device which is essentially required for making the equipment operational is required to be supplied along with the equipment and n additional cost.
35. Printed conditions of the tenders shall not be binding on CIMFR.
36. CIMFR is an R&D organization under CSIR, Ministry of Science & Technology, Govt. of India. Therefore it is requested to **quote concessional rates applicable to the R&D organizations since the equipment is required for research purposes.**
37. Offers for stores vaguely described as "Best Indian Make", "Foreign Make" will be ignored while considering the tenders.
38. Details of Equipments supplied to CSIR Labs/Institutes: The tenderers who have supplied identical or similar equipment to other CSIR Labs/Institutions have to furnish the details of such supplies for the preceding three years along with the prices eventually or finally paid positively.
39. **Responsibility:** The responsibility lies with the successful tenderer, if any damage or loss to the property of the Institute occurs while undertaking and executing the contract.
40. **Shortage of Supplies:** Suppliers will have to make the good the shortages, if any, which is revealed after opening the packages. The Stores, which are spoiled/damaged during transit due to faulty packing will have to be replaced by the suppliers. The product should have warranty for workmanship, performance and service for a minimum period of twelve months from the date of acceptance of replacement of spares/parts during warranty period. The replacement should be done free of all costs including to and fro Air Freight, packing, forwarding and insurance charges.
41. **Defects and Liability Period:** Thirty six months from the date of virtual completion, installation and commissioning of the equipments as certified by CIMFR, Dhanbad, India.
42. **Damage and Unaccepted supply :** The material found to be damaged and declared rejected should be collected by you at your risks and costs within 21 days from the date of intimation by CIMFR, otherwise ground rent will be charged.
- In addition to the Terms and Conditions mentioned above, Terms and Conditions for the items offered from abroad are as follows:
43. The detailed specifications of the material offered should be given. Relevant technical Literature and descriptive catalogue / pamphlet should also be attached with the offer.
44. **FOB Price only to be indicated.** Other charges applicable to be indicated separately.
45. **INSURANCE:** Insurance will be done by our own means for imports. Please intimate immediately after shipment about the Airway Bill No. For indigenous items the cost must include the insurance charges.

Bill of Lading, consignment etc. to The Director, CIMFR, P.O + Dist: Dhanbad, Dhanbad, Jharkhand, India.

**46. WARRANTY:** Warranty period should be for a minimum period of **three years onsite comprehensive**.

**47. COUNTRY OF ORIGIN:** Please specify Place/County of Origin and the Place/Country from where goods will be finally shipped. These particulars are very important for establishment of Letter of Credit and arranging insurance.

**48. VALIDITY PERIOD:** Your offer should be valid for at least One Hundred Eighty (180) days from the date of opening of tenders.

49. Please also indicate names and addresses of some of the Indian Organizations to whom you have supplied material, if any, under reference.

50. This Institute is eligible for payment of concessional customs duty under OGL Scheme. Actual User-Condition (Non-industrial-R&D institution).

**51. INDIAN AGENT'S COMMISSION:** If you have any Agent in India, please indicate specifically whether the amount of agency commission payable to the agent is included in the FOB Price or not. Moreover, Indian Agent should have compulsory registration with DGS&D, Govt. of India (**wherever required on case to case basis**). Please note that the tender will not be considered if the Indian Agent is not Compulsorily registered with DGS&D, Govt. of India and Agency Commission will not be paid to the Indian Agent unless a legible photocopy of DGS&D Registration Certificate duly attested is submitted to this office. The Indian Agents Commission will be paid in Indian Rupees only within thirty days from the date of commissioning and final acceptance of the whole system by CIMFR, Dhanbad-828 108, India. The role played by the Indian Agents in rendering assistance to your customers may also be specified.

**52. FREIGHT:** The mode of dispatch should be Ocean Freight/Air Freight preferably by Air India Flight and on To-Pay basis only. Please indicate the approximate Air Freight Charges for Kolkata Air Port, India. The consignments are required to be shipped by Air India (Freight to pay) up to Kolkata Airport, India. All the documents are to be made in favour of Director, CIMFR, Dhanbad-826 001, India and forwarded to our Banker.

For speedy clearance, please specify our Purchase Order Reference No. and date on the top of the parcel as well as on the Airway bill without fail. Address all the consignments to **Director, CIMFR, Dhanbad-826 015**, India and not to Bank. The ordered materials are being imported under Open General License.

The following documents may be sent to us directly while dispatch.

Invoice in quadruplicate with deduction of Agency Commission, if any, Packing List, Delivery Challan, Country of Origin Certificate, Literature, if any, should be enclosed.

### **53. PAYMENT TERMS :**

**Term I - In case of indigenous orders, the payment will be on credit basis i.e. 100% after receipt of material in good condition, installation, testing, commissioning, satisfactory demonstration, final acceptance of the whole system and on submission of unconditional Performance Bank Guarantee for 10% of the total order value valid till 60 days after the warranty period from a Indian Scheduled Bank duly recognized by RBI.**

**Term II - In case of import orders, 80 percent value of goods will be paid through an Irrevocable Letter of Credit on submission of shipping documents. Balance 20 percent value of goods will be paid through L/C excluding Indian Agency Commission, if any, after installation, testing, commissioning, satisfactory demonstration, final acceptance of the whole system and on submission of unconditional Performance Bank Guarantee for 10% of the total order value valid till 60 days after the warranty period from a Foreign Bank duly endorsed by Nationalized Bank in India.**

**Term III - 100% payment after satisfactory installation & commissioning of the equipment if it is to be supplied for the first time in India or otherwise if the party does not have successful installation in India, against submission of unconditional Performance Bank Guarantee for 10% of the total order value within twenty one (21) days of the placement of Purchase Order valid till 60 days after the warranty period from a Foreign Bank duly endorsed by Nationalized Bank in India. Director, CIMFR reserves the right to change the payment terms at his discretion from case to case basis depending on the merit of the case.**

54. The tenders are liable to be cancelled if any of the conditions noted herein are not complied with. Hypothetical, ambiguous and conditional tenders will not be entertained at all and rejected summarily.

**55. Goods should not be dispatched until firm Purchase Order is received by the successful vendor.**

56. Director, CIMFR reserves the right to delete or alter the item given in the enclosed annexure depending on prevailing requirements.

57. Director, CIMFR reserves the right to accept or reject any tender in completely or in part thereof without assigning any reason.

**58. Arbitration :**

Except where otherwise provided in the Contract, all questions and disputes relating to the meaning of the specifications, instructions and terms & conditions herein before mentioned and as to the quality of the materials, as to any question, claim, right, matter or thing whatsoever, in any way arising out of or relating to the Contract. Specifications, estimates, instructions, orders

or these conditions or otherwise concerning the works, or the execution of the same whether arising during the process of the work or after the completion or abandonment thereof shall be **referred to the sole arbitration of a person nominated by the Director General, Council of Scientific & Industrial Research, New Delhi**, and if he is unable or unwilling to act to the sole arbitration of some other person appointed by him willing to act as such arbitrator. The submission shall be deemed to be submission to Arbitration under the meaning of the India Arbitration & Conciliation, 1996 or any satisfactory modification or reenactment thereof for the time being in force conclusive and binding on all parties of the Contract. **The venue of the arbitration will be Dhanbad only.**

**In the case of a dispute between the purchaser and a foreign supplier, the dispute shall be settled by arbitration in accordance with provision of clause above. But if this not acceptable to the supplier then the dispute shall be settled in accordance with provisions of UNCITRAL (United Nations Commission of International Trade Law) Arbitration Rules. The venue of the arbitration shall be the place from where the order is issued.**

## **SECTION - IV**

### **FORMATS FOR BID SUBMISSION** **Checklist for Bid Submission**

The following check-list must be filled in and submitted with the bid document:

#### **Technical Bid:**

<b>1.</b>	Has the tender document issued to you?	Yes / No
<b>2.</b>	Have you attached the technical bid form?	Yes / No
<b>3.</b>	Have you attached a copy of the last audited balance sheet of your firm?	Yes / No
<b>4.</b>	Have you attached proof of the manufacturer's authorization?	Yes / No
<b>5.</b>	Have you attached the details of the income tax registration and latest income tax clearance certificate?	Yes / No
<b>6.</b>	Have you attached the statement of deviations from the technical Specifications in the format?	Yes / No
<b>7.</b>	Have you provided details of your maintenance infrastructure facilities including addresses of the service centers in the format	Yes / No
<b>8.</b>	Have you attached the technical details of the goods and services offered as a part of this bid document?	Yes / No
<b>9.</b>	Have you attached the copies of relevant work orders executed during the last three years?	Yes / No
<b>10.</b>	<b>Have you attached the details of identical or similar equipments supplied to other CSIR Labs/Institutes for the preceding three years together with prices eventually or finally paid?</b>	Yes / No
<b>11.</b>	<b>Have you attached photocopy duly attested of Certificate of compulsory Enlistment of Indian Agents of foreign principals with DGS&amp;D if quoting on their behalf? Date of enlistment must be before the date of opening of tenders.</b>	Yes / No
<b>12.</b>	Have you attached Service Provider Certificate issued by the Manufacturer?	Yes / No

# Financial Bid:

1.	Have you attached the Financial Bid?	Yes / No
2.	Have you attached the price schedule for the goods/services offered in the Format?	Yes / No
3.	Have you attached the statement of deviations from the Financial terms and conditions in the format?	Yes / No

Please arrange your tender document for each part as given below:

## **Earnest Money Deposit :**

### **TECHNICAL BID:**

#### **Technical Bid Form**

Copy of the Last Audited Balance Sheet of the company

Income Tax Registration Certificate/PAN No.and latest Income Tax Clearance Certificate

Proof of Manufacturer's authorization

Photocopy of Warranty Service Provider Agreement between the manufacturer and the Service Provider.

Statement of Deviation from the technical specifications

Details of service centers at Dhanbad

Photocopy duly attested of Certificate of compulsory enlistment of Indian Agents of foreign principals with DGS&D if quoting on their behalf. Date of enlistment must be before the date of opening of tenders?

Copies of relevant work orders

Details of supplies of identical or similar equipment made to other CSIR Labs/Institutions for the preceding three years together with price eventually or finally paid.

### **FINANCIAL BID:**

#### **Financial Bid Form**

Estimated quantity and Financial Bid Analysis

Statement of Deviations from Financial terms and conditions

# Technical Bid Form

(To be submitted on the firm's Letter Head and signed by an authorized person)

To ,  
The Director  
Central Institute of Mining & Fuel Research  
P.O. DHANBAD Barwa Road,  
DHANBAD – 826015, Jharkhand,INDIA

**Ref: Tender No.CIMFR/PUR/14(1)2010 dt.16.07.2010.**

Sir,

Having examined the bidding documents, the receipt of which is hereby duly acknowledged, we, the undersigned offer to supply and deliver goods as per the schedule of requirements and in conformity with the said bidding documents.

We undertake, if our bid is accepted, to deliver the goods in accordance with the delivery schedule specified in the bidding documents.

If our bid is accepted, we will submit a unconditional performance bank guarantee for the sum equivalent to 10% of the Contract Price i.e. Total Order Value for the due performance of the Contract, in the form prescribed by the Central Institute of Mining & Fuel Research, Dhanbad.

We agree to abide by this bid for a period of One Hundred Twenty days after the date fixed for opening and it shall remain binding upon us and may be accepted at any time before the expiration of that period.

We declare that we are the manufacturers/authorized agents/distributor of

---

that we/our principals are equipped with adequate machinery for production, quality control and testing of offered products manufactured/developed and used by us.

2. We hereby offer to supply the Goods/Services at the price at the rates mentioned in the Financial Bid.

3. We enclose herewith the complete Technical Bid as required by you. This includes:

## Technical Bid Form

Copy of the last audited balance sheet of the company

Proof of Manufacturers authorization.

Technical details of the goods and services offered.

Statement of deviation from the technical specifications

Details of local service centers

Product catalogues/user manual/other informative material about our products and Services.

Details of supplies of identical or similar equipment to other CSIR Labs/Institutes for the preceding three years together with prices eventually or finally paid.

Photocopy duly attested of Certificate of compulsory enlistment of Indian Agents of Foreign principals with DGS&D if quoting on their behalf. Date of enlistment (It must be before the date of opening of tenders).

4. We have carefully read and understood the terms and conditions of the bid document and the conditions of the contract applicable to the bid document and we do hereby undertake to supply as per these terms and conditions.

5. Certificate that the bidder is:

A Sole proprietorship firm and the person signing the bid document is the sole proprietor/constituted attorney of the sole proprietor, or

A partnership firm, and the person signing bid document is a partner of the firm and he has authority to refer to arbitration disputes concerning the business of the partnership by virtue of the partnership agreement/by virtue of general power of attorney, or

A company and the person signing the document is the constituted attorney.

**(NOTE: Delete whatever is not applicable. All correction/deletions should invariable by duly attested by the person authorized to sign the bid document)**

6. We do hereby undertake take, until a formal work order is prepared and executed, this bid, together with your written acceptance thereof and placement of letter of intent awarding the work order, shall constitute a binding contract between us.

Dated this day 2004 Signature of Bidder

**Details of enclosures.**

**Full Address** \_\_\_\_\_

**Telephone No.** \_\_\_\_\_

**Telegraphic Address:** \_\_\_\_\_

**Fax No** \_\_\_\_\_

**E-Mail** \_\_\_\_\_

**COMPANY SEAL**

**STATEMENT OF DEVIATIONS FROM TECHNICAL SPECIFICATIONS AND  
SCHEDULE OF REQUIREMENTS**

Following are the Technical deviations and variations from the Technical specifications and Schedule of Requirements. These deviations and variations are exhaustive. Except these deviations and variations, the entire work shall be performed as per your specifications and documents.

SI No.	Item	Statement of Deviations / Variations

Signature of the Bidder

Name:

Date:

Place:

Address:

Company Seal

**MAINTENANCE INFRASTRUCTURE FACILITIES INCLUDING ADDRESSES OF  
THE LOCAL SERVICES CENTRES**

<b>LOCATION</b>	<b>ADDRESS OF SERVICE CENTRE</b>	<b>NAME OF THE CONTACT PERSON WITH TEL. No. Fax No. and Email</b>	<b>Total No. of qualified service engineers</b>	<b>Remarks</b>

**Signature of the Bidder**

**Name:**

**Date:**

**Place:**

**Address:**

**Company Seal**

## Financial Bid Form

(On the Letter Head of the firm submitting the Bid Document)

To  
The Director  
Central Institute of Mining & Fuel Research  
P.O.DHANBAD, DISTT: DHANBAD  
PIN - 826015, Jharkhand, INDIA

**Ref: Tender No. CIMFR/PUR/14(1)2010 dt.16.07.2010.**

Sir,

Having examined the bidding documents and having submitted the technical bid for the same, we, the undersigned, hereby submit the Financial Bid for supply of goods and services as per the schedule of requirements and in conformity with the said bidding documents.

We hereby offer to supply the Goods/Services at the prices and rates mentioned in the Financial Bid.

We do hereby undertake that, in the event of acceptance of our bid, the supply of Goods/Services shall be made as stipulated in the schedule to the Bid document and that we shall perform all the incidental services.

The prices quoted are inclusive of all charges including installation and commissioning charges in the Central Institute of Mining & Fuel Research Institute, Dhanbad.

We enclose herewith the complete Financial Bid as required by you. This includes:

Financial Bid Letter

Price Schedule

Statement of deviations from Financial terms and conditions.

We agree to abide by our offer for a period of One Hundred Twenty (120) days from the date fixed for opening of the bid documents and that we shall remain bound by a communication of acceptance within that time.

We have carefully read and understood the terms and condition of the bid document and we do hereby undertake to supply as per these terms and conditions. The Financial Deviation are only those mentioned in the statement of deviation from financial terms and conditions.

Certified that the bidder is:

A sole proprietorship firm and the person signing the bid document is the sole proprietor/constituted attorney of sole proprietor.

Or

A partnership firm and the person signing the bid document is a partner of the firm and he has authority to refer to arbitration disputes concerning the business of the partnership by virtue of the partnership agreement/by virtue of general power of attorney.

Or

A company and signing the bid document is the constituted attorney.

(Note: Delete whatever is not applicable. All corrections/deletions should invariably be duly attested by the person authorized to sign the bid document).

We do hereby undertake, that until a formal work order is prepared and executed, this bid, together with your written acceptance thereof and placement of letter of intent awarding the work order, shall constitute a binding contract between us.

Dated this day of \_\_\_\_\_ Signature of Bidder

Details of enclosures

Full Address:

Telephone No.

Telegraphic Address:

E-mail:

COMPANY SEAL

**PRICE SCHEDULE - Estimated Quantity and Financial Bid Analysis**

Sl No	Item Name	Qty.	Manufacturer	Model Name & Version	Compliance to suggested Technical Specification	Operating System Environment	Unit Cost Rs.	Total cost (inclusive of all other charges)

1. Attach sheet giving detailed Technical Specification and deviations for the suggested systems.

**NOTE**

- (i) For Financial bid comparison total Value in Col. No. 9 shall be the basis.
- (ii) Unit value quoted in actual quantity of work shall form the basis.
- (iii) The Bid should have Col. 3 x Col. 8 = Col.9. Any error in the Table of any bidder is liable to be out rightly rejected.
- (iv) The price quoted should be inclusive of all charges including all applicable taxes, Octroi, freight and handling charges, and all other miscellaneous expenses.
- (v) In case of discrepancy between unit price and total price, the unit price will prevail.
- (vi) Annual Maintenance Charges after warranty period should be quoted separately.

Signature of the bidder

Name :

Place :

Date :

Address :

Company Seal

## **STATEMENT OF FINANCIAL DEVIATIONS**

Following are the financial deviations and variation(s) from the exceptions to the specifications and documents for the Bid document. These deviation(s) and variation(s) are exhaustive.

Except these deviation(s) and variation(s), the entire work shall be performed as per your specifications and documents.

<b>SI No.</b>	<b>Section No.</b>	<b>Clause No.</b>	<b>Statement of Deviations / Variations</b>

S. No. Section No. Clause No. Statement of deviation(s) and variation(s)

Signature of the bidder

Name:

Place:

Date:

Address:

Company Seal

**PRICE SCHEDULE FOR GOODS BEING OFFERED FROM ABROAD**

Name of the Bidder : \_\_\_\_\_

TENDER No.: \_\_\_\_\_

1	2	3	4	5	6	7	8	9			
Sl. No.	Item Description	Country of origin	Unit	Qty.	Unit Price		Total Price(5x6)		Charges for Insurance & transportation to port/place of destination		Total Price (7+8) CIF
					FOB (named port of shipment)	FCA (named place of delivery)	FOB (named port of shipment)	FCA (named place of delivery)	Ocean	Air	

**Note:**

**Currency**

(a) Indian agents name and address \_\_\_\_\_ in words.

(b) Installation, commissioning & training charges, if any.

(c) Cost of spares: \_\_\_\_\_

Address : \_\_\_\_\_

(d) The Indian Agent's commission shall be paid in Indian Rupees only based on the Exchange Rate prevailing on the date of negotiation of documents in accordance with clause 22.1 of GCC.

(e) The cost of optional items shall be indicated separately.

**Total Bid Price in Foreign**

**Signature of Bidder**

**Name**

**Business**

**PRICE SCHEDULE FOR GOODS BEING OFFERED FROM INDIA**

Name of the Bidder : \_\_\_\_\_

Tender No.: \_\_\_\_\_

<u>1</u>	<u>2</u>	<u>3</u>	<u>4</u>	<u>5</u>	<u>6</u>	<u>7</u>	<u>8</u>	<u>9</u>	<u>10</u>	<u>11</u>
Sl. No.	Item Description	Country of Origin	Unit	Qty.	Ex-works/ Ex-ware house/ Ex-showroom off the shelf price (inclusive of all taxes already paid)	Total Price Ex-Works / Ex-ware house/ Ex-showroom off the shelf price (inclusive of all taxes already paid) 5x6	VAT & other taxes like excise duty payable, if contract is awarded	Packing & forwarding upto station of dispatch, if any	Charges for inland transportation, Insurance upto Lab./Instt.	Installation, Commissioning and Training Charges, if any

Total Bid Price in Foreign  
Currency in words:  
Signature of Bidder

Name : \_\_\_\_\_

Address : \_\_\_\_\_

Note: (a) The cost of optional items shall be indicated separately.  
(b) Cost of Spares.

**BID SECURITY FORM**

WHEREAS

.....  
(hereinafter called "the Bidder") has submitted its bid dated  
.....(Date of submission of bid) for the supply of  
.....(Name and/or description of the  
goods) (Hereinafter called "the bid").

KNOW ALL PEOPLE by these presents that WE  
.....(Name of bank) of  
..... (Name of country), having our registered  
office at (address & phone & fax no. of bank) (hereinafter called "the bank"), are  
bound unto ..... (Name of Purchaser)  
(hereinafter called "the Purchaser") in the sum of  
..... For which payment well and  
truly to be made to the said purchaser, the Bank binds itself, its successors, and  
assigns by these presents, Sealed with the common Seal of the said Bank this  
..... Day of ..... 200.....  
THE CONDITIONS of this obligation are:

1. If the Bidder withdraws its Bid during the period of bid validity specified by the Bidder on the Bid Form; or
2. If the Bidder, having been notified of the acceptance of its bid by the Purchaser  
During the period of bid validity:
  - a) Fails or refuses to execute the Contract Form if required; or
  - b) Fails or refuses to furnish the performance security, in accordance with Instruction to Bidders.

We undertake to pay the purchaser up to the above amount upon receipt of its first written demand, without the Purchaser having to substantiate its demand, provided that in its demand the Purchaser will note that the amount claimed by it is owing to it, owing to the occurrence or one or both of the two conditions, specifying the occurred condition or conditions.

This guarantee shall remain in force up to and including 180 (One Hundred Eighty) days after the period of the bid validity, and any demand in respect thereof should reach the Bank not later than the above date.

**PERFORMANCE SECURITY FORM**

To: \_\_\_\_\_ (Name of Purchaser)  
WHEREAS \_\_\_\_\_ (Name of Supplier)  
hereinafter called "the Supplier" has undertaken, in pursuance of Contract No. \_\_\_\_\_ dated \_\_\_\_\_ 2007 to supply \_\_\_\_\_  
(Description of Goods and Services) hereinafter called "the Order" AND WHEREAS it has been stipulated by you in the said order that the Supplier shall furnish you with a Bank Guarantee by a recognized bank for the sum specified therein as security for compliance with the Supplier's performance obligations in accordance with the order.

AND WHEREAS we have agreed to give the Supplier a Guarantee:  
THEREFORE WE hereby affirm that we are Guarantors and responsible to you, on behalf of the Supplier, up to a total of \_\_\_\_\_  
(Amount of the Guarantee in Words and Figures) and we undertake to pay you, upon your first written demand declaring the sum or sums within the limit of \_\_\_\_\_  
(Amount Guarantee) as aforesaid, without your needing to prove or to show grounds or reasons for your demand or the sum specified therein.

This guarantee is valid until the \_\_\_\_\_ day of \_\_\_\_\_

**Signature and Seal of Guarantors**

Date

**Address**

All correspondence with reference to this guarantee shall be made at the following address:

\_\_\_\_\_  
\_\_\_\_\_  
\_\_\_\_\_

\_\_\_\_\_  
(Name & address of the lab)

2	<p>File No:- CIMFR/PUR/-14(19)2010</p> <p><b><u>Vehicle Mounted (portable ) Gas Analyzer System</u></b> for measuring Gases Emissions from Coal Mine Fire areas located in Jharia &amp; Ranigaj Coal field. All those interested/prospective bidders are invited/ requested to kindly send their consent on our before 13.12.2010 for participating in this pre-indent conference schedule to be held on 14.12.2010 at CIMFR, Barwa Road, Dhanbad.</p> <p><b><u>Technical Details:-</u></b></p> <p>Gas Analyzer System consisting of collector, sampler and analyzer which can be mounted /fitted on a vehicle, to be used in open cast coal mine fire areas. Minimum requirement:</p> <ol style="list-style-type: none"> <li>1. The system should be able to measure CO<sub>2</sub>, CH<sub>4</sub></li> <li>2. Additional measuring facility for CO,SO<sub>x</sub>,NO<sub>x</sub>&amp;N<sub>2</sub>O</li> <li>3. Data logger to store data</li> <li>4. PC/Laptop to operate the system and retrieve data.</li> <li>5. Preparation/modification of vehicle existing with CIMFR for successful installation of analyzers</li> <li>6. UPS/generator of suitable capacity to operate the system.</li> <li>7. A tentative design of heat and fire resistant portable chamber for gas collection from mine fire cracks/areas and assembly with analyzers(<b>annexure</b>). Arrangements must be made to take care of following: High temperature and moisture of sample gas. Variable concentration ( Very low or Very high) sample gas.</li> <li>8. <b><u>Warranty:</u></b> Three-year comprehensive including spares, with calibration of the instrument and AMC for next two years should be quoted.</li> <li>9. The warranty also includes the responsibility of supplier to carry out minimum three month monitoring at site with satisfactory outcome.</li> </ol> <p>Kindly send your consent to the following personal</p> <ol style="list-style-type: none"> <li>1. Dr. Siddhartha Singh, Sct.E-I , E-mail : <a href="mailto:ssgcmri@yahoo.com">ssgcmri@yahoo.com</a>, Mob.No.+ 919431122769</li> <li>2. Stores &amp; Purchase Officer, E-mail: <a href="mailto:spo.cmri@nic.in">spo.cmri@nic.in</a>, Fax No:- 0326-2296030</li> </ol> <p style="text-align: center;"><b>For details please visit our website <a href="http://www.cimfr.nic.in">www.cimfr.nic.in</a></b></p>	One Unit
---	--	----------

Annexure I

Gas collection chamber design and specification for mine fire gas collection from cracks in opencast mines.

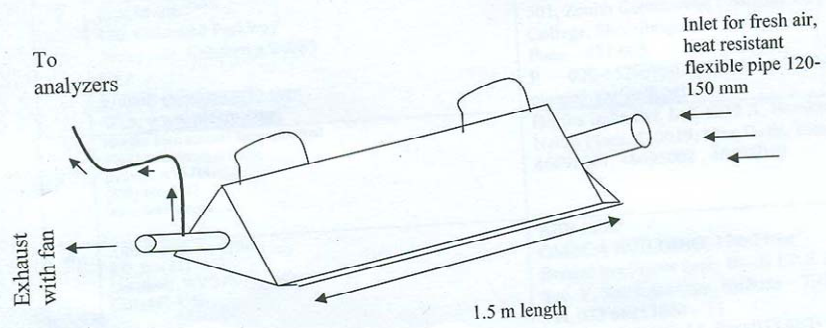

**Material:** Fire and heat resistant, preferably light weight